



PALADIN[®]

HARLEY

www.paladinattachments.com



MINI POWER RAKES

FOR COMPACT TOOL CARRIERS

Paladin's D4 Mini Power Box Rake is an advanced version of the classic Harley design, designed to be compatible with most compact tool carriers. This versatile rake offers manual or hydraulic angle adjustment options and is known for delivering the high-level performance that our customers have come to expect when it comes to preparing seed beds, grading soil, and leveling gravel.

MINI POWER RAKES

FOR COMPACT TOOL CARRIERS

FEATURES

- Direct drive motor is embedded within frame and drum providing optimal protection from dirt and debris.
- Adjustable barrier crafted from eco-friendly recycled aircraft rubber
- Specially shaped and placed carbide teeth ensure the best possible seedbed
- End plates that can be removed easily and gates that can be adjusted to multiple positions
- Dual independently adjustable gauge wheels

SPECIFICATIONS

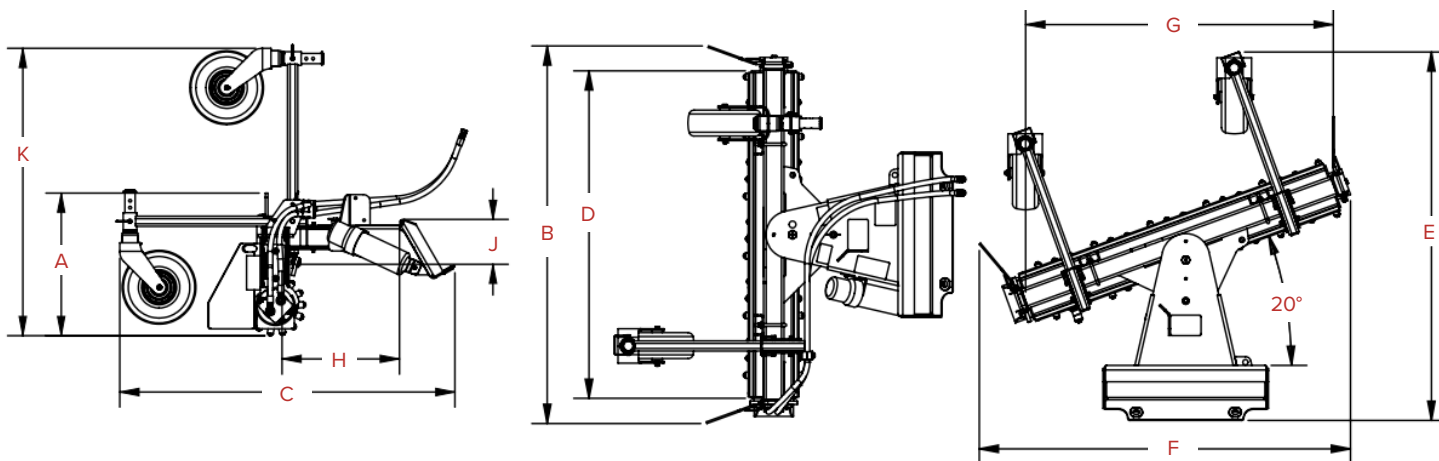

| | 22748M-0961 | 22748H-0961 |
|-----------------------------------|--------------|-----------------|
| STYLE | Manual Angle | Hydraulic Angle |
| A. OVERALL HEIGHT | 20.8 IN. | 20.8 IN. |
| B. OVERALL WIDTH | 55.4 IN. | 55.4 IN. |
| C. OVERALL LENGTH | 49.1 IN. | 49.1 IN. |
| D. RAKING WIDTH | 48 IN. | 48 IN. |
| F. OVERALL WIDTH @ 20° | 54.5 IN. | 54.5 IN. |
| E. OVERALL LENGTH @ 20° | 54.1 IN. | 54.1 IN. |
| G. RAKING WIDTH @ 20° | 45.2 IN. | 45.2 IN. |
| H. CENTER OF GRAVITY - HORIZONTAL | 17.2 IN. | 17.2 IN. |
| J. CENTER OF GRAVITY - VERTICAL | 6.5 IN. | 6.5 IN. |
| K. OVERALL HEIGHT - CASTER UP | 42.1 IN. | 42.1 IN. |
| WEIGHT | 365 LBS | 380 LBS |
| REQUIRED FLOW | 8-15 GPM | 8-15 GPM |
| MAXIMUM PRESSURE | 3000 PSI | 3000 PSI |